

FEATURES

- | Standard CMOS process.
- | Embedded 1M EPROM.
- | 42 Sec Voice Length at 6 KHz sampling and 4-bit ADPCM compression.
- | 20-pin 8-Trigger or 16-pin 4-Trigger selectable by MODE pad bonding option.
- | Maximum 32 (8-Trigger version) /12 (4-Trigger version) voice groups.
- | Combination of voice building blocks to extend playback duration.
- | 960 table entries are available for voice block combinations.
- | User selectable PCM or ADPCM data compress.
- | Two triggering modes are available by whole chip option during voice compilation.
 - Key Trigger Mode – Combinations of S1 ~ S8 to trigger up to 32 voice groups; SBT for sequential trigger.
 - CPU Parallel Trigger Mode – Combinations of S1 ~S5 with SBT goes HIGH to strobe start the voice playback.
- | Voice Group Trigger Options: Edge / Level; Hold / Un-hold; Retrigger / Non-retrigger.
- | Whole Chip Options: Ramp / No-ramp; Output Options; Key / CPU trigger mode.
- | 16ms (@ 8KHz sampling rate) Debounce Time for both Key CPU Trigger Mode.
- | RST pin set to HIGH to stop playback at once.
- | Three user programmable outputs for STOP plus, BUSY signal and flashing LED.
- | Built-in oscillator to control sampling frequency with an external resistor.
- | 2.2V – 3.6V single power supply and < 5uA low stand-by current.
- | PWM Vout1 and Vout2 drive speaker directly.
- | D/A COUT to drive speaker through an external BJT.
- | Development System support voice compilation and options selection.

DESCRIPTION

aP89042 high performance Voice OTP is fabricated with Standard CMOS process with embedded 1M bits EPROM. It can store up to 42 sec voice message with 4-bit ADPCM compression at 6KHz sampling rate. 8-bit PCM is also available as user selectable option. Two trigger modes, simple Key trigger mode and Parallel CPU trigger mode facilitate different user interface. User selectable triggering and output signal options provide maximum flexibility to various applications. Built-in resistor controlled oscillator, 8-bit current mode D/A output and PWM direct speaker driving output minimize the number of external components. PC controlled programmer and developing software are available.

PIN CONFIGURATIONS

16-Pin Version

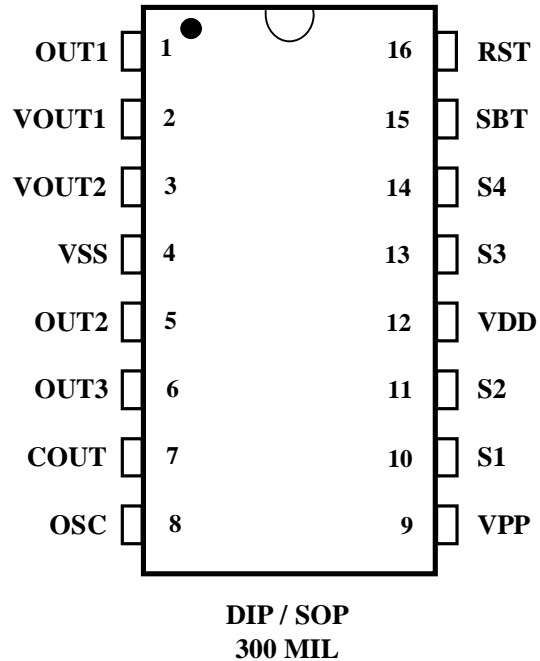

PIN NAMES

PIN	Playback Mode	OTP Program Mode	Description
1	OUT1	-	Programmable output (I/O pin)
2	VOUT1	-	PWM output to drive speaker directly
3	VOUT2	-	PWM output to drive speaker directly
4	VSS	VSS	Power Ground
5	OUT2	OEB	Programmable output (I/O pin)
6	OUT3	IO	Programmable output (I/O pin)
7	COUT	-	D/A current output
8	OSC	ACLK	Oscillator input
9	VPP	VPP	Supply voltage for OTP programming
10	S1	S1	Trigger pin (input with internal pull-down)
11	S2	S2	Trigger pin (input with internal pull-down)
12	VDD	-	2.4 – 3.6V Positive Power Supply
13	S3	S3	Trigger (input with internal pull-down)
14	S4	S4	Trigger (input with internal pull-down)
15	SBT	PGM	Trigger pin (input with internal pull-down)
16	RST	DCLK	Reset pin (input with internal pull-down)

PIN DESCRIPTIONS

S1 ~ S4

Input Trigger Pins:

- S1 to S8 is used to trigger the 12 Voice Groups in both Key and CPU Parallel Trigger Mode.
 - In OTP Programming Mode, S1 to S4 are used as program enable pins.
-

SBT

Input Trigger Pin:

- In Key Trigger Mode, this pin is trigger pin to trigger the playback of Voice Groups one by one sequentially.
 - In CPU Parallel Command Mode, this pin is used as address strobe to latch the input from S1 to S4 and starts the voice playback.
 - In OTP Programming Mode, this pin is used as PGM signal.
-

VDD

Power Supply Pin.

VSS

Power Ground Pin

VOUT1 and VOUT2

Digital PWM output pins which can drive speaker and buzzer directly for voice playback.

OSC

During voice playback, an external resistor is connected between this pin and the VDD pin to set the sampling frequency. In OTP Programming Mode, this is the ACLK input signal.

VPP

Connection to VDD is required during voice playback. In OTP Programming Mode, this pin is connected to a separate 6.5V power supply.

OUT1, OUT2 and OUT3

- In Key Trigger Mode and CPU Parallel Command Mode, these pins are user programmable pins for the STOP pulse, BUSY and LED signals.
 - During OTP programming, OUT2 serves as OEB while OUT3 serves as data IO.
-

COUT

Analog 8-bit current mode D/A output for voice playback

RST

Chip reset in playback mode or DCLK pin in OTP programming mode.

VOICE SECTION COMBINATIONS

Voice files created by the PC base developing system are stored in the built-in EPROM of the aP89042 chip as a number of fixed length Voice Blocks. Voice Blocks are then selected and grouped into Voice Groups for playback. Up to 32 Voice Groups are allowed. A Voice Block Table is used to store the information of combinations of Voice Blocks and then group them together to form Voice Group.

Chip	aP89042
Memory size	1M bits
Max no. of Voice Block	252
No. of bytes per Voice Block	512
Max. no. of Voice Group	12
No. of Voice Table entries	960
Voice Length (@ 6KHz 4-bit ADPCM)	42 sec

Example of Voice Block Combination

Assume here we have three voice files, they are “How are You?”, Sound Effect and Music. Each of the voice file is divided into a number of fixed length Voice Block and stored into the memory.

Voice File 1 - “How are You?” is stored in Voice Block B0 to B12.

Voice File 2 - Sound Effect is stored in Voice Block B13 to B15.

Voice File 3 - Music is Voice Block B16 to B40.

Voice Blocks are grouped together using Voice Table to form Voice Group for playback:

Group no.	Voice Group contents	Voice Table Entries
Group 1	“How are You?”	B0 ... B12
Group 2	Sound Effect + “How are You?”	B13 ... B15 + B0 ... B12
Group 3	“How are You?” + Music	B0 ... B12 + B16 ... B40
Group 4	Music	B16 ... B40

Voice Data Compression

Voice File data is stored in the on-chip EPROM as either 4-bit ADPCM or 8-bit PCM format. Voice data stored as 4-bit ADPCM provides 2:1 data compression which can save 50% of memory space. On the other hand, voice data are stored as 8-bit PCM format means no data compression is employed but voice playback quality will be better.

Programmable Options

In both Key Trigger Mode and CPU Parallel Trigger Mode, user can select different trigger functions and output signals to be sent out from the pins OUT1, OUT2 and OUT3.

Options affect all Voice Group playback are called Whole Chip Options. Options only affect the playback of individual Voice Group are called Group Options.

Whole Chip Options

- Key or CPU Parallel Trigger Mode.
- Ramp-up-down enable or disable:

When COUT is used for playback, Ramp-up-down should be enabled. This function eliminates the ‘POP’ noise at the beginning and end of voice playback.

When VOUT1 and VOUT2 are used to drive speaker directly, Ramp-up-down should be disabled.

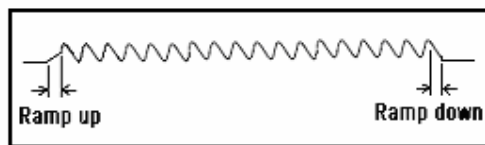

Fig. 1 Ramp-up-down Enable

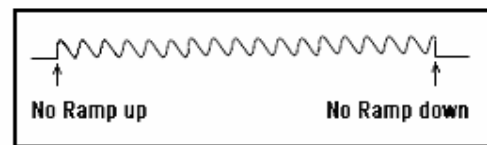

Fig.2 Ramp-up-down Disable

- Output Options:

This option sets up the three output pins OUT1 and OUT2 to send out different signals during voice playback. Four settings are allowed:

	OUT1	OUT2	OUT3
Option 1	LED2	LED1	BUSY
Option 2	STOP	LED1	LED2
Option 3	LED1	BUSY	STOP
Option 4	LED1	BUSY	/BUSY

Note: Stop plus and BUSY must be set to enable in order to have STOP plus and BUSY high to come out.

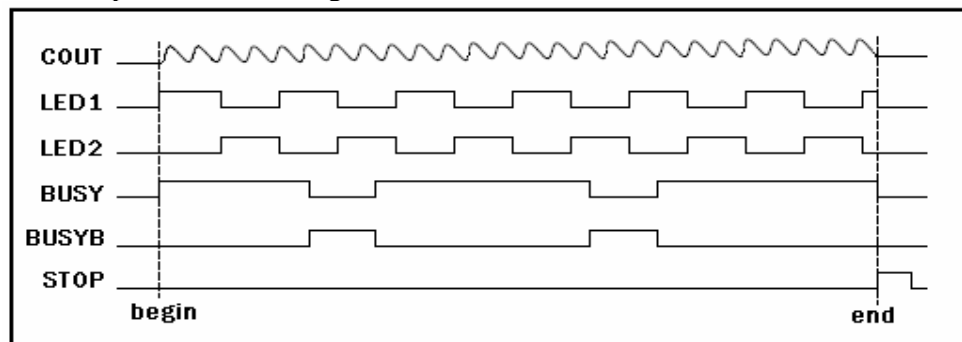

Fig. 3 Output waveforms

Group Options

User selectable options that affect each individual group are called Group Options. They are:

- Edge or Level trigger
- Unholdable or Holdable trigger
- Re-triggerable or non-retriggerable
- Stop pulse disable or enable

Fig. 4 to Fig. 9 show the voice playback with different combination of triggering mode and the relationship between outputs and voice playback.

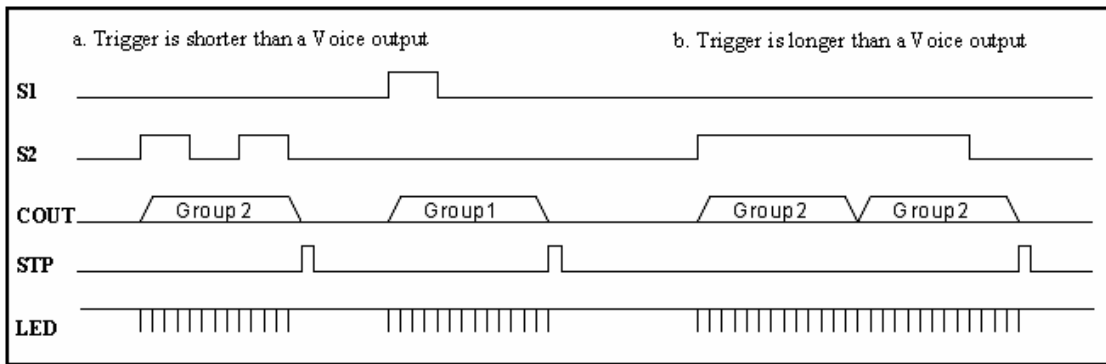

Fig. 4 Level, Unholdable, Non-retriggerable

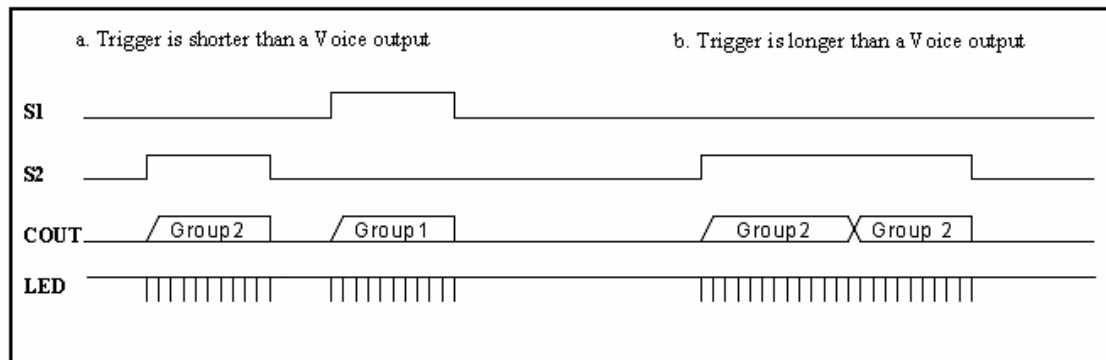

Fig. 5 Level Holdable

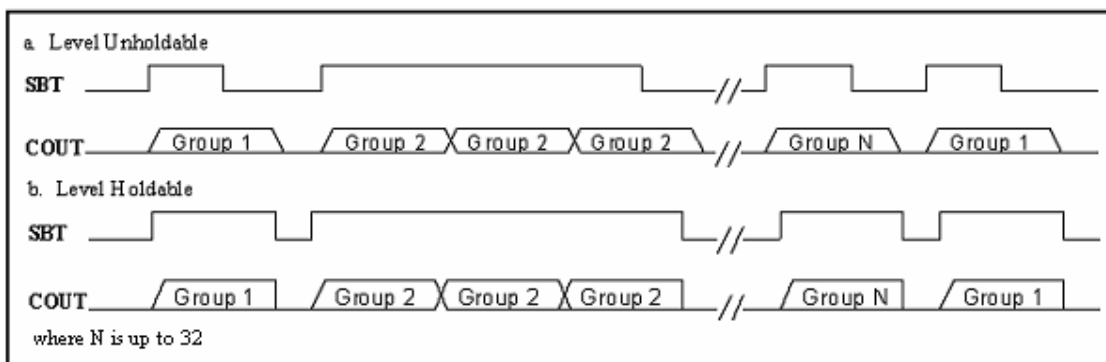

Fig. 6 SBT sequential trigger with Level Holdable and Unholdable

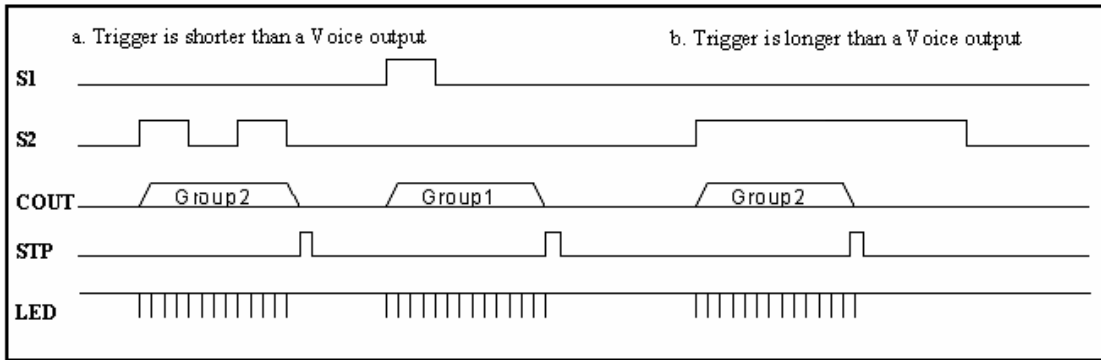

Fig. 7 Edge, Unholdable, Non-retrigger

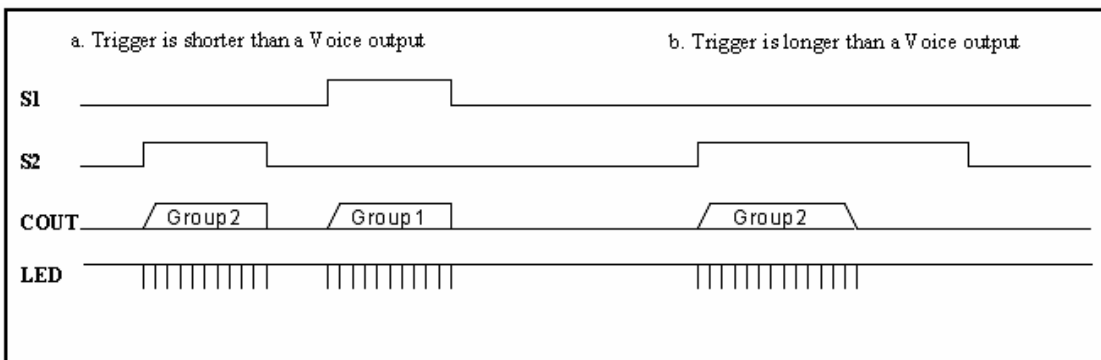

Fig. 8 Edge, Holdable

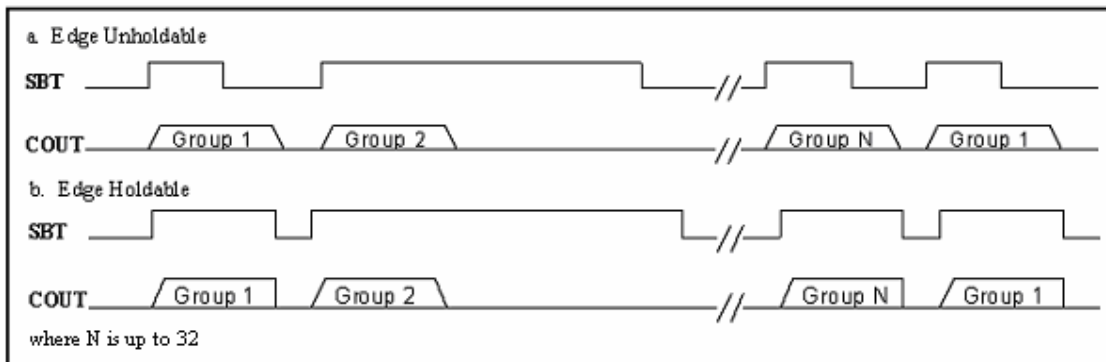

Fig. 9 SBT sequential trigger with Edge Holdable and Unholdable

Overlap trigger is supported with Level/Unholdable trigger options:

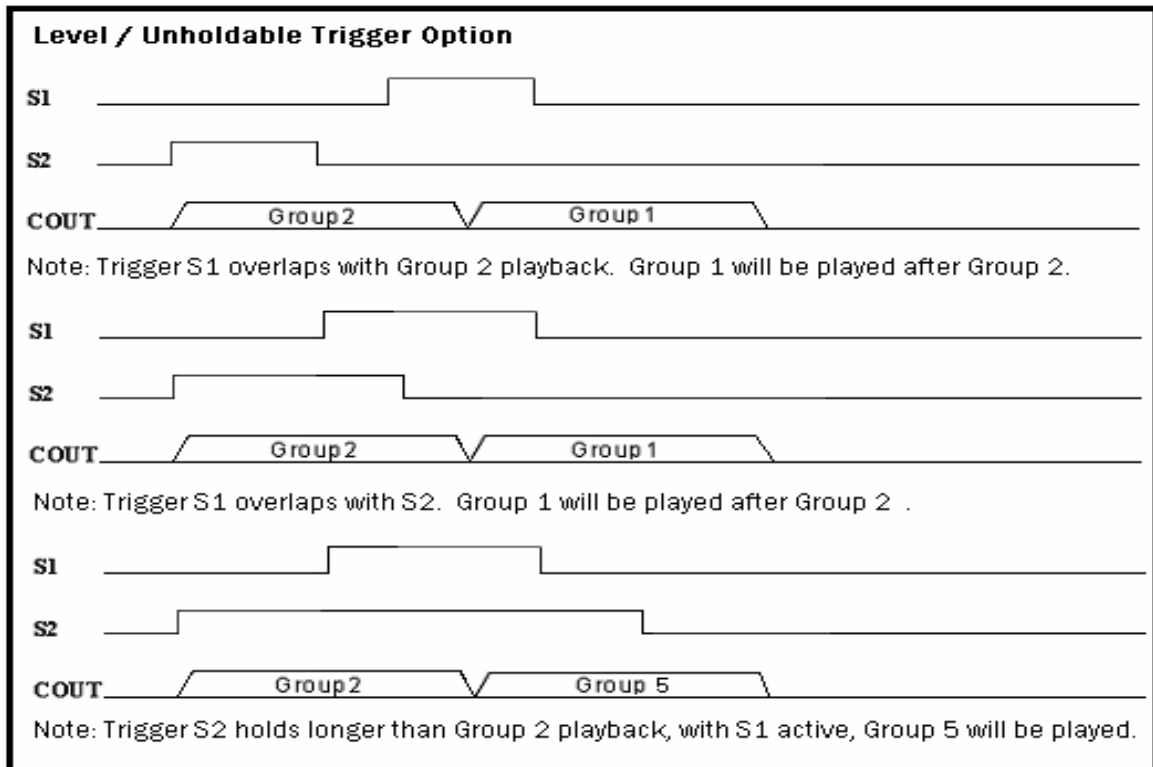

Fig. 10 Overlap trigger

TRIGGER MODES

There are two package forms available with aP89042. The MODE pad is used by bonding option to set the package form.

When the MODE pad is left unconnected, the chip is set to 20-pin package.
When the MODE pad is connected to Vdd, the chip is set to 16-pin package.

Key or CPU Trigger modes are determined by setting the EPORM programmable options during voice data compilation.

Key Trigger Mode

With this trigger mode, up to 12 (16-pin version) Voice Groups are triggered by setting S1 to S4 to HIGH or NC (not connected) in different combinations. Each Voice Group can have its only independent trigger options (See Fig. 4, 5, 7 and 8 for trigger options definition).

Voice Groups can also be triggered sequentially by setting SBT pin to HIGH.

CPU Parallel Trigger Mode

In this mode, S1 to S5 are set to HIGH or LOW according to the table above and followed by setting the SBT input pin to HIGH, the corresponding Voice Group will be triggered.

Trigger options defined in Fig. 4, 5, 7 and 8 are valid for this mode.

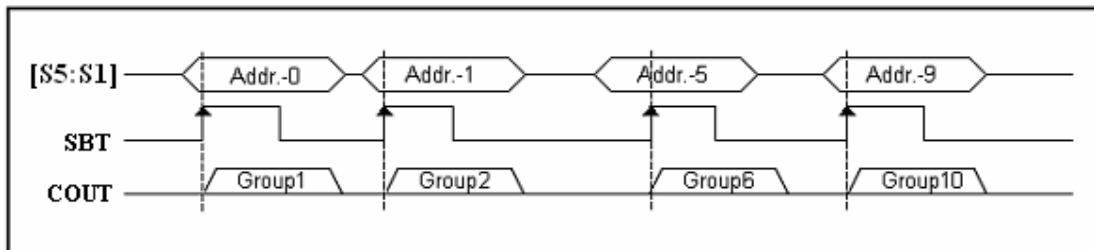

Fig. 11 CPU Parallel Trigger Mode

Note that SBT pin cannot be used as Single Button Sequential trigger in this mode. In stead, it acts as a Strobe input to clock-in the data input from S1 to S5 into the chip.

16-Pin Key Trigger Mode (MODE pad = Connect to VDD)

Up to 12 Voice Groups can be triggered by S1 to S4.

Voice Group	S1	S2	S3	S4
1	HIGH	NC	NC	NC
2	NC	HIGH	NC	NC
3	NC	NC	HIGH	NC
4	NC	NC	NC	HIGH
5	HIGH	HIGH	NC	NC
6	NC	HIGH	HIGH	NC
7	NC	NC	HIGH	HIGH
8	HIGH	NC	NC	HIGH
9	HIGH	HIGH	HIGH	NC
10	NC	HIGH	HIGH	HIGH
11	HIGH	NC	HIGH	HIGH
12	HIGH	HIGH	NC	HIGH

16-Pin CPU Trigger Mode (MODE pad = Connect to VDD)

Up to 12 Voice Groups can be triggered by supplying address to [S4:S1] with SBT as strobe signal.

Voice Group	S4	S3	S2	S1
1	0	0	0	0
2	0	0	0	1
3	0	0	1	0
4	0	0	1	1
5	0	1	0	0
6	0	1	0	1
7	0	1	1	0
8	0	1	1	1
9	1	0	0	0
10	1	0	0	1
11	1	0	1	0
12	1	0	1	1

BLOCK DIAGRAM

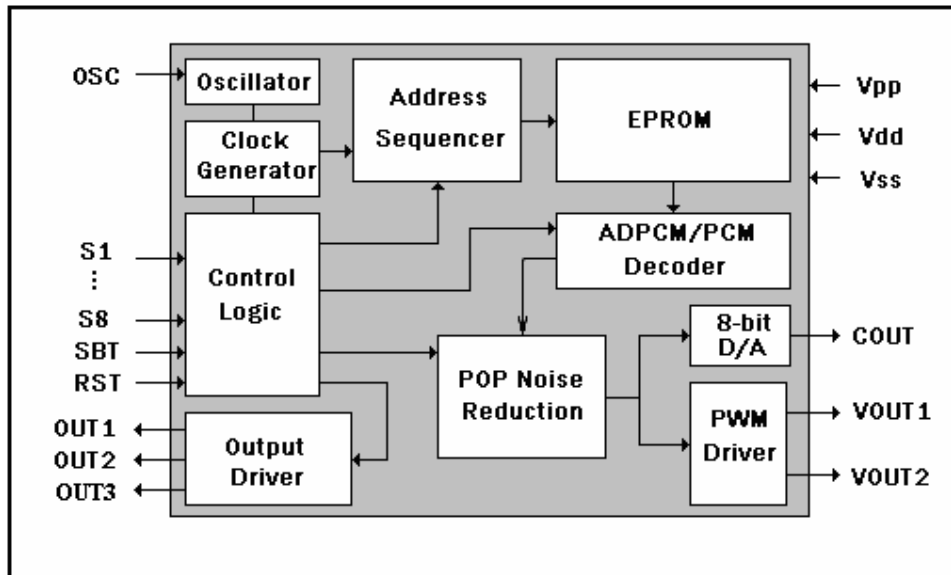

ABSOLUTE MAXIMUM RATINGS

Symbol	Rating	Unit
$V_{DD} - V_{SS}$	-0.5 ~ +4.5	V
V_{IN}	$V_{SS} - 0.3 < V_{IN} < V_{DD} + 0.3$	V
V_{OUT}	$V_{SS} < V_{OUT} < V_{DD}$	V
T (Operating)	-10 ~ +60	°C
T (Storage)	-55 ~ +125	°C

DC CHARACTERISTICS ($T_A = 0$ to 70°C , $V_{DD} = 3.3\text{V}$, $V_{SS} = 0\text{V}$)

Symbol	Parameter	Min.	Typ.	Max.	Unit	Condition
V_{DD}	Operating Voltage	2.2	3.0	3.6	V	
I_{SB}	Standby current	—	1	5	μA	I/O open
I_{OP}	Operating current	—	—	15	mA	I/O open
V_{IH}	"H" Input Voltage	2.5	3.0	3.5	V	$V_{DD}=3.0\text{V}$
V_{IL}	"L" Input Voltage	-0.3	0	0.5	V	$V_{DD}=3.0\text{V}$
I_{OL}	V_{OUT} low O/P Current	—	120	—	mA	$V_{out}=0.3\text{V}$, $V_{DD}=3.0\text{V}$
I_{OH}	V_{OUT} high O/P Current	—	-120	—	mA	$V_{out}=2.5\text{V}$, $V_{DD}=3.0\text{V}$
I_{CO}	C_{OUT} O/P Current	—	-3	—	mA	$V_{COUT}=1.0\text{V}$, $V_{DD}=3.0\text{V}$
I_{OH}	O/P high Current	—	-8	—	mA	$V_{OH}=2.5\text{V}$, $V_{DD}=3.0\text{V}$
I_{OL}	O/P low Current	—	8	—	mA	$V_{OL}=0.3\text{V}$, $V_{DD}=3.0\text{V}$
$\Delta F/F$	Frequency Stability	-5	—	+5	%	$\frac{F_{osc}(2.7\text{V}) - F_{osc}(3.4\text{V})}{F_{osc}(3\text{V})}$

TIMING WAVEFORMS

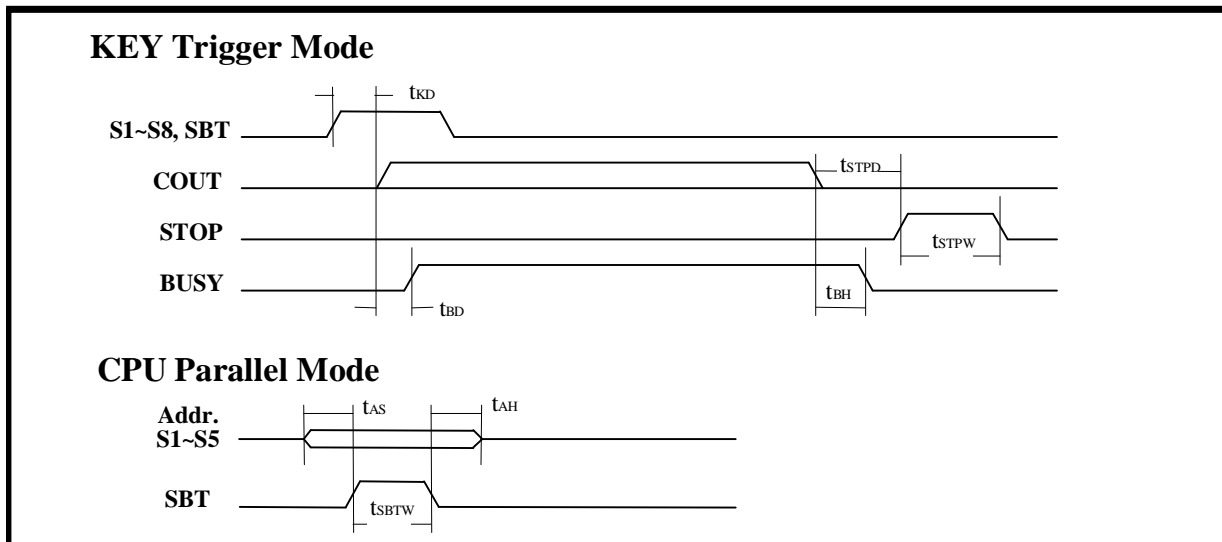

AC CHARACTERISTICS (T_A = 0 to 70°C, V_{DD} = 3.3V, V_{SS} = 0V, 8KHz sampling)

Symbol	Parameter	Min.	Typ.	Max.	Unit	Note
t _{KD}	Key trigger debounce time	16	—	—	ms	1
t _{KD}	Key trigger debounce time – retrigger	24	—	—	ms	1
t _{STPD}	STOP pulse output delay time	—	—	256	μs	
t _{STPW}	STOP pulse width	—	64	—	ms	1
t _{BD}	BUSY signal output delay time	—	—	100	ns	
t _{BH}	BUSY signal output hold time	—	100	—	ns	
t _{AS}	Address set-up time	100	—	—	ns	
t _{AH}	Address hold time	100	—	—	ns	
t _{SBTW}	SBT stroke pulse width	65	—	—	μs	1
t _{LEDC}	LED flash frequency	—	3	—	Hz	2

Notes :

1. This parameter is inversely proportional to the sampling frequency.
2. This parameter is proportional to the sampling frequency.

OSCILLATOR RESISTANCE TABLE

Sampling Frequency KHz	R _{OSC} KOhm
4.90	300
5.26	290
5.88	280
6.09	270
6.33	260
6.67	250
6.85	240
7.14	230
7.46	220
7.70	210
8.06	200
8.47	190
8.93	180
9.26	170
9.80	160
10.42	150

R _{OSC} KOhm	Sampling Frequency KHz
140	11.00
130	11.76
120	12.50
110	13.33
100	14.51
91	15.63
82	16.95
75	18.18
68	19.23
62	20.83
56	22.22
51	23.81
43	25.00

Note: The data in the above tables are within 3% accuracy and measured at $V_{DD} = 3.0V$. Oscillator frequency is subjected to IC lot to lot variation.

TYPICAL APPLICATIONS

Key Trigger Mode

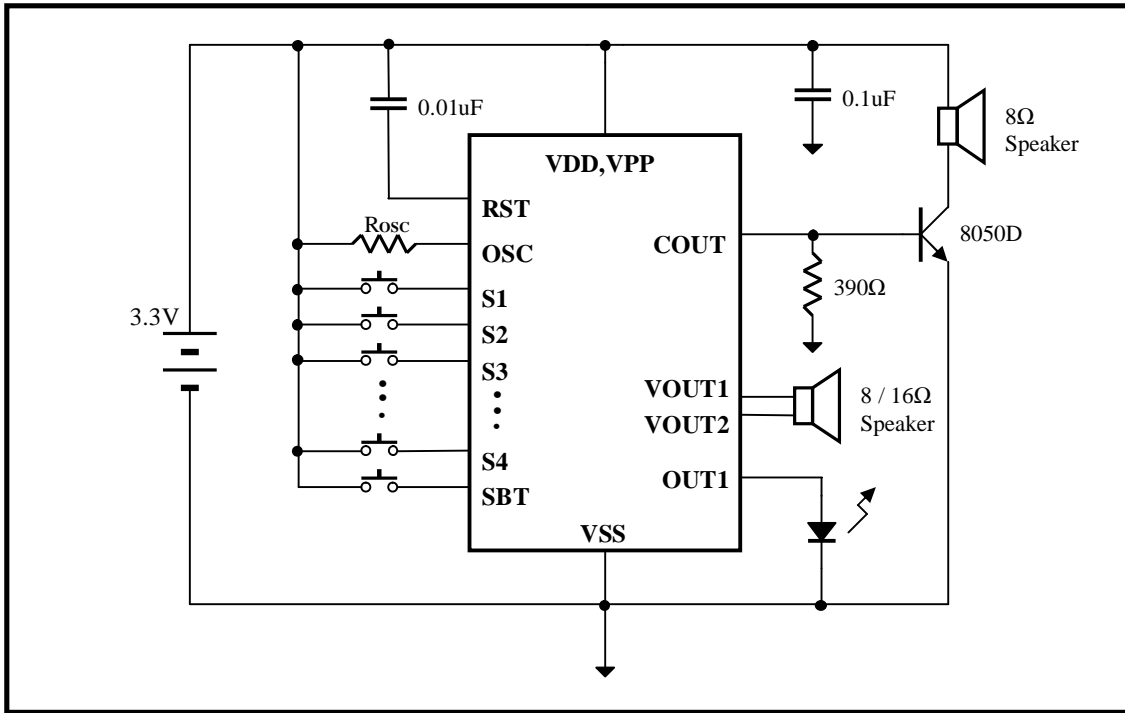

Fig. 12 Using 3.3V Battery

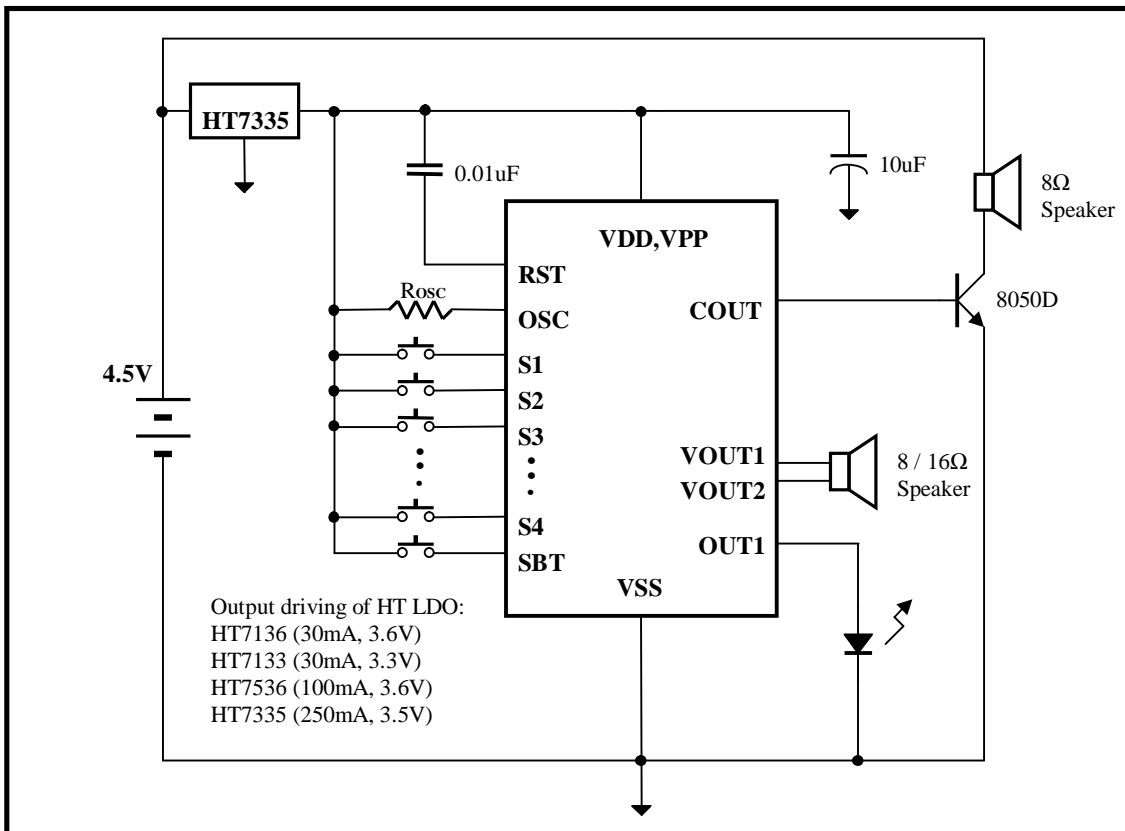

Fig. 13 Using 4.5V Battery

CPU Parallel Mode

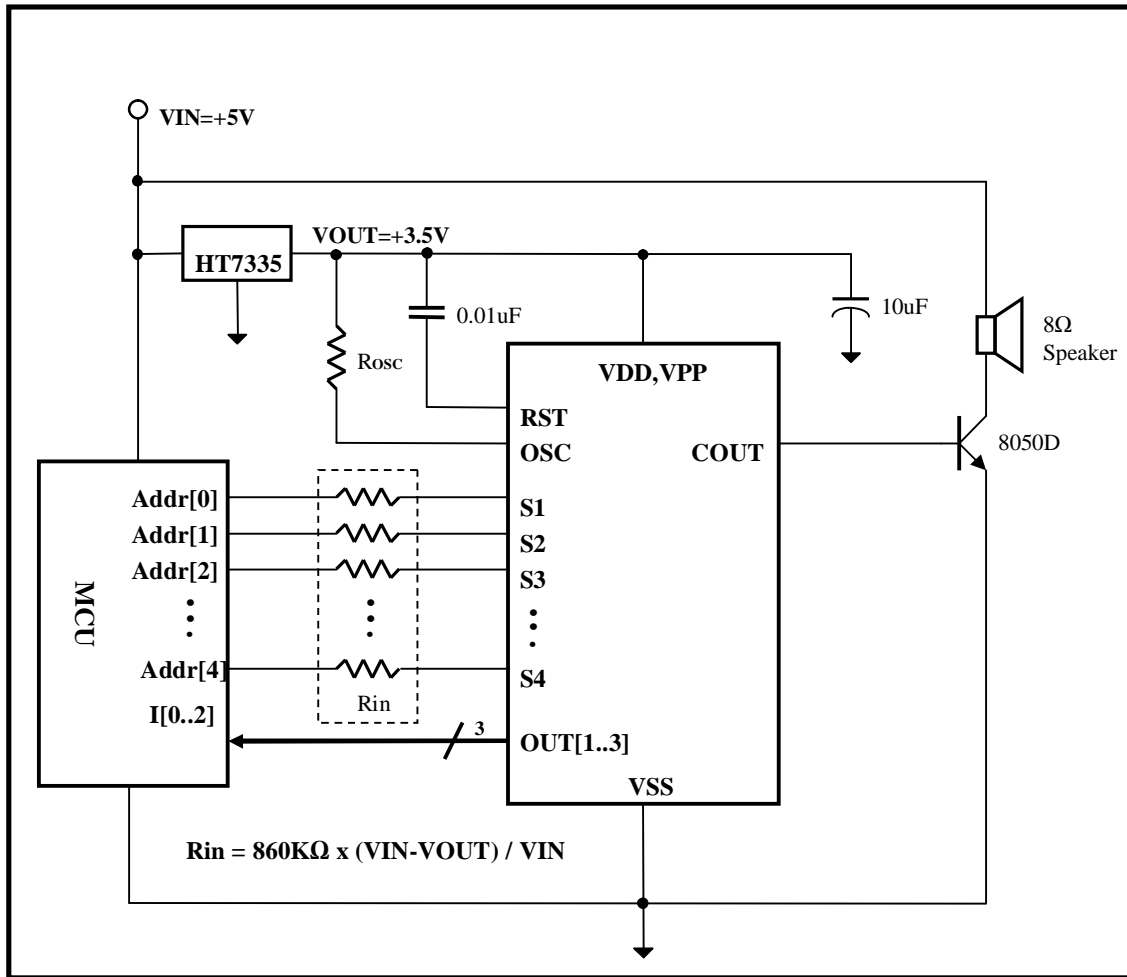

Fig. 14 5V CPU Control with COUT

Bonding Diagram



(0, 0)

Bonding pad size: 80um x 90um

MODE pad not connected: 20-pin version, S5 to S8 are enabled.

MODE pad connected to VDD: 16-pin version, S5 to S8 are disabled.

Pad Name	Location (X,Y)
VDD	2199.83, 1276.99
MODE	1918.34, 1281.99
S3	1652.19, 1281.99
S4	1448.56, 1281.99
SBT	1182.62, 1281.99
RST	978.99, 1281.99
S7	713.23, 1281.99
S8	509.60, 1281.99
OUT1	243.99, 1281.99
VOUT1	173.70, 1014.23
VOUT2	713.70, 614.27

Pad Name	Location (X,Y)
VSS	173.70, 358.65
OUT2	173.70, 138.00
OUT3	439.31, 138.00
COUT	642.94, 138.00
OSC	1276.09, 138.00
S5	1745.66, 138.00
S6	1949.29, 138.00
VPP	2200.12, 299.45
S1	2200.09, 834.58
S2	2200.09, 1038.21

PACKAGES DIMENSION OUTLINES

16-Pin 300mil P-DIP Package

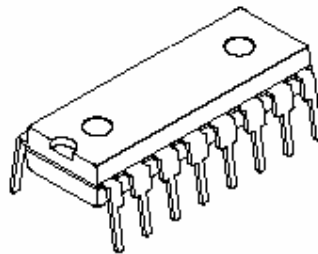
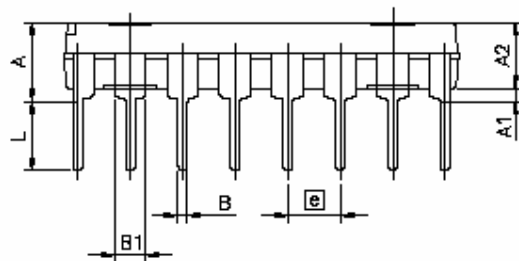
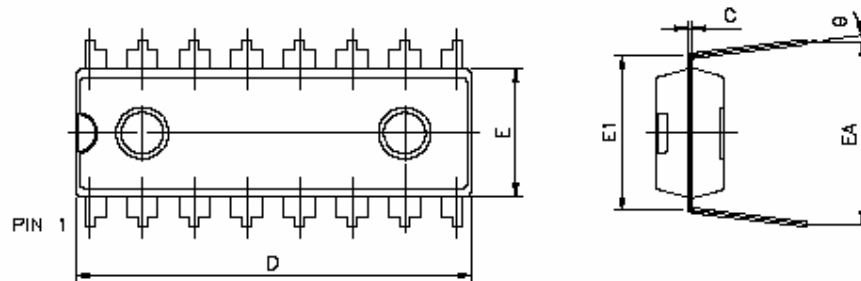

SYMBOL	DIMENSION IN INCH	DIMENSION IN MM
A	0.170 MAX.	4.318 MAX.
A1	0.015 MIN.	0.381 MIN.
A2	0.130±0.005	3.302±0.127
B	0.018 TYP.	0.457 TYP.
B1	0.060 TYP.	1.524 TYP.
C	0.010 NOM.	0.254 NOM.
D	0.752±0.005	19.101±0.127
E	0.252±0.005	6.401±0.127
E1	0.300±0.010	7.62±0.254
EA	0.355±0.020	9.017±0.508
e	0.100 TYP.	2.540 TYP.
L	0.130±0.010	3.302±0.254
θ	0°~15°	0°~15°

NOTE:
1.DIMENSION D & E DOES NOT INCLUDE FLASH.

Device Compatibility Cross Reference

aP89042					
		20-Pin Version		16-Pin Version	
		Key Mode	CPU Mode	Key Mode	CPU Mode
8208A	Key Trigger			0	
840N	Key Trigger	0			
aP8821	Key Trigger			0	
	CPU Trigger				0
aP8842	Key Trigger	0			
	CPU Trigger		0		