

# AR9301-V2

## Single-Chip Voice Recording & Playback Device for Single 20 to 30 Second Message

### Features

- Single-chip, high quality voice recording & playback solution
  - No external ICs required
  - Minimum external components
- Non-volatile Flash memory technology
  - No battery backup required
  - 100K record cycles (typical)
  - 100-year message retention (typical)
- Single message of 20 to 30 seconds, with external resistor selection
- User-friendly, easy-to-use operation
  - Programming & development systems not required
  - Level-activated recording & edge-activated playback switches
- Low power consumption
  - Operating current: 25 mA (typical, no load)
  - Standby current: 1uA (typical, no load)
- Automatic power-down feature for longer battery life
- Chip enable pin for simple message expansion
- Single 6 V power supply

### General Description

The AR9301 device offers true single-chip solid-state storage capability and requires no software or microcontroller support. It provides high-quality recording and playback with a single 20- to 30-second message. It is ideal for portable voice recorders, toys, and many other consumer and industrial applications.

APLUS integrated analog/multi-level storage technology is implemented in advanced Flash non-volatile memory cells, each of which can typically store more than 256 voltage levels. The AR9301-V2 stores and reproduces voice signals in their natural forms, eliminating the distortion that is often introduced by encoding and compression. The device combines a small size with low power consumption, non-volatility, and ease-of-use for a cost effective solution to voice recording and playback.

**Figure 2 AR9301 -V2 Functional Block Diagram**

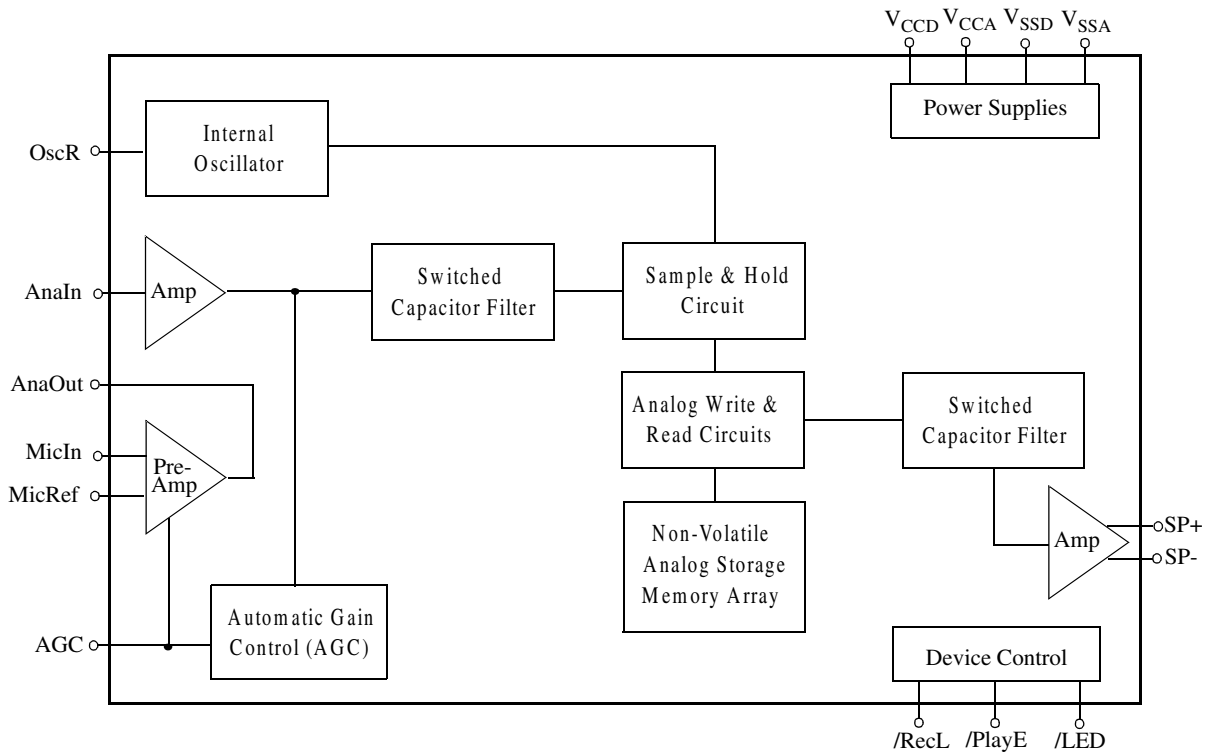

### Sample Application

Figure 3 shows the diagram for a single, 20-second message recording and playback application using the APR9301 device. When pins are connected as shown in this example, the operating modes are as follows:

#### Record Mode (Level-Activated)

A single voice message of up to 20 seconds can be recorded. The /LED pin will go low during the actual recording process to provide a visual indication if an LED light is connected to this pin. The chip is in record mode as long as the /RecL pin stays low (level-activated). If the message lasts longer than 20 seconds, recording will terminate automatically after the last available memory cell is written. If the message is shorter than 20 seconds, the recording operation will stop when the /RecL pin goes high. The speaker driver is automatically tristated during the recording operation.

Messages of up to 30 seconds can be recorded by using different OscR resistor values (see Table 1).

#### Playback Mode (Edge-Activated)

Playback always starts from the beginning of the message. The chip is in playback mode after the /PlayE pin pulses low (edge-activated). Playback will stop immediately when the /PlayE pin pulses low a second time. If the newly recorded message is shorter than the previously recorded message, the remaining portion of the previous message will not be played after the new message is played back. The input pre-amplifier, AGC, and main amplifier circuits are disabled during playback.

#### Standby Mode (/CE = "0")

The chip will automatically return to the standby state after recording or playback operation is completed.

#### Power Down Mode (/CE = "1")

The chip is always in standby state. No recording or playback is allowed. Current consumption is typically less than 1 A.

**Figure 3 Sample Applicatio**

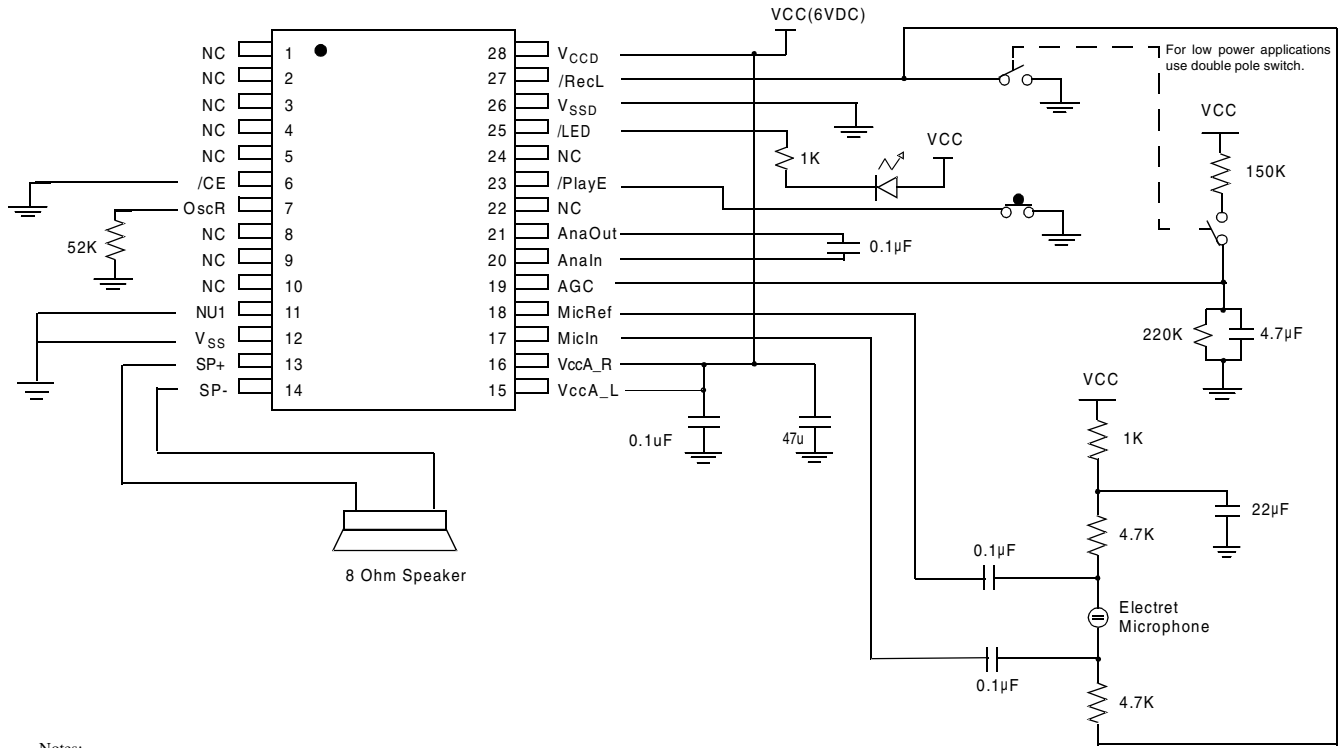

Notes:  
 NC = No Connect (must be floating).  
 Pins 23 and 27 have internal pull-up resistors.  
 The typical sampling frequency is 6.4 kHz with OscR = 52 k .      *Substrate should be connected to GND.*

**Table 1 Typical Dependence of Sampling Frequency and Total Voice Duration on OscR Resistor Value**  
 ( $V_{CCA} = V_{CCD} = 6V$ ;  $V_{SSA} = V_{SSD} = 0V$ ;  $T_A = 25^\circ C$ )

Pin 7 - OscR	Typical Sampling Frequency	Cutoff Frequency (3 dB Point)	Typical Total Voice Duration
38 k	8 kHz	3.4 kHz	16 seconds
52 k	6.4 kHz	2.7 kHz	20 seconds
67 k	5.3 kHz	2.3 kHz	24 seconds
89 k	4.0 kHz	1.7 kHz	32 seconds

Figure 4 shows the same application using external microphone biasing instead of the microphone amplifier on the AR9301 -V2 , thus bypassing the preamplifier portion of the chip function.

**Figure 4 Sample Application Using External Microphone Biasing**

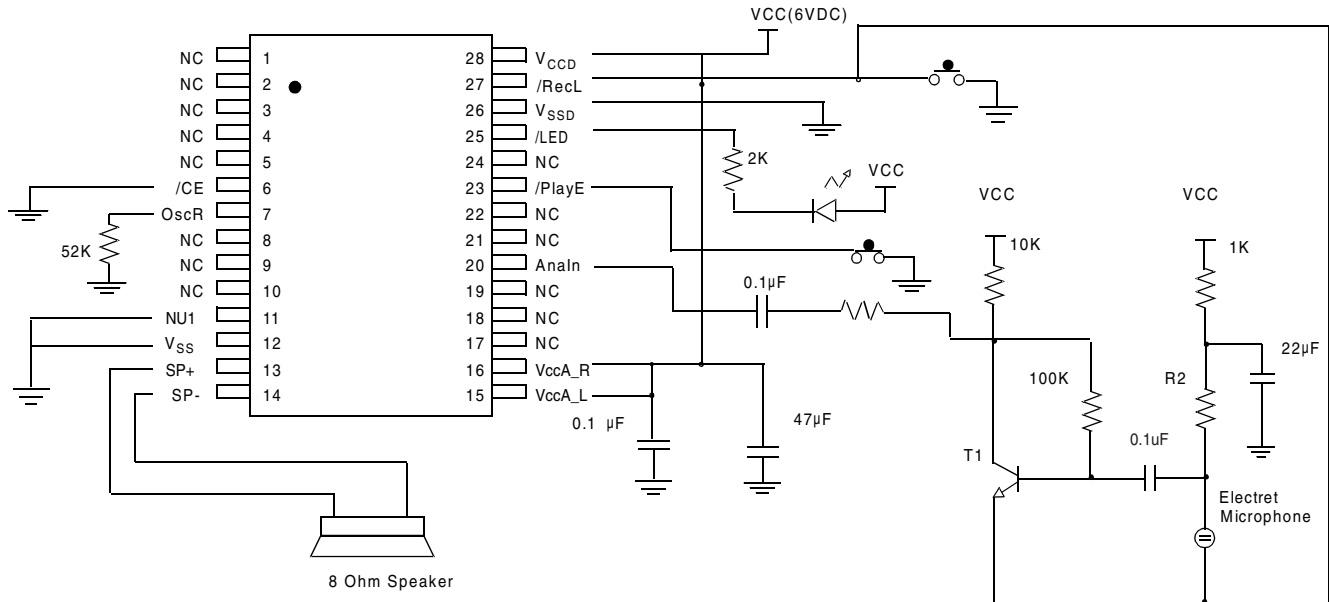

Notes:  
 NC = No Connect (must be floating).  
 Pins 23 and 27 have internal pull-up resistors.  
 The typical sampling frequency is 6.4 kHz with OscR = 52 k .  
 NPN bipolar transistor, T1 model #MPS3904 or equivalent.  
 R1 and R2 are recommended to be 30 k and 10 k , respectively, for typical applications.

Substrate should be connected to GND.

**Electrical Characteristics**

Tables 2 through 4 list Absolute Maximum Ratings, Recommended DC Characteristics, and recommended Analog Characteristics for the AR9301-V2 device.

**Absolute Maximum Ratings**

Stresses greater than those listed in Table 2 may cause permanent damage to the device. These specifications represent a stress rating only. Operation of the device at these or any other conditions above those specified in the recommended DC Characteristics or recommended Analog Characteristics of this specification is not implied. Operation of the device at maximum conditions for extended periods may affect reliability.

**Table 2 Absolute Maximum Ratings.**

Item	Symbol	Condition	Min	Max	Unit
Power Supply Voltage	$V_{CC}$	$T_A = 25\text{ }^\circ\text{C}$	4.5	6.5	V
Input Voltage	$V_{IN1}$	$T_A = 25\text{ }^\circ\text{C}$	-0.3	$V_{CC} + 0.3$	V
Input Voltage	$V_{IN2}$	$ I_{IN}  < 20\text{ mA}$	-1.0	$V_{CC} + 1.0$	V
Storage Temperature	$T_{STG}$	-	-65	150	$^\circ\text{C}$
Temperature Under Bias	$T_{BS}$	-	-65	125	$^\circ\text{C}$
Lead Temperature	$T_{LD}$	$< 10\text{ s}$	-	300	$^\circ\text{C}$

**Table 3 DC Characteristics** <sup>Note 1</sup>

Item	Symbol	Condition	Min	Typ	Max	Unit
Input High Voltage	$V_{IH}$	-	$0.8 V_{CC}$	x	-	V
Input Low Voltage	$V_{IL}$	-	-	-	0.8	V
Output High Voltage	$V_{OH}$	$I_{OH} = -1.6\text{ mA}$	2.4	-	-	V
Output Low Voltage	$V_{OL}$	$I_{OL} = 4.0\text{ mA}$	-	-	0.45	V
Input Leakage Current	$I_{IH}$	$V_{IH} = V_{CC}$	-	-	1.0	$\mu\text{A}$
Input Leakage Current	$I_{IL}$	$V_{IL} = V_{SS}$ <sup>Note 2</sup>	-1.0	-	-	$\mu\text{A}$
Output Tristate Leakage Current	$I_{OZ}$	$V_{OUT} = V_{CC}$ or $V_{OUT} = V_{SS}$	-1.0	-	1.0	$\mu\text{A}$
Operating Current Consumption	$I_{CC}$	Internal Clock, No Load	-	25	-	mA
Standby Current Consumption	$I_{CCS}$	No Load	-	1.0	-	$\mu\text{A}$

**Table 4 Analog Characteristics** <sup>Note 1</sup>

Item	Symbol	Condition	Min	Typ	Max	Unit
MicIn Input Voltage	$V_{MI}$	-	-	-	20	mV <sub>P-P</sub>
MicIn Input Resistance	$R_{MI}$	-	-	10	-	k
MicIn Amp Gain (1)	$G_{MI1}$	$AGC \leq 2.2\text{ V}$	-	24	-	dB
MicIn Amp Gain (2)	$G_{MI2}$	$AGC \geq 3.0\text{ V}$	-	-45	-15	dB
AnaIn Input Voltage	$V_{ANI}$	-	-	-	50	mV <sub>P-P</sub>
AnaIn Input Resistance	$R_{ANI}$	-	-	10	-	k
AnaIn Amp Gain	$G_{ANI}$	AnaIn to SP+/-	-	22	-	dB
AGC Output Resistance	$R_{AGC}$	-	-	1	-	k
SP+/- Output Power	$P_{SP}$	$R_{SP+/-} = 16$	-	12.2	-	mW
Voltage Amplitude Across SP+/-	$V_{SP}$	$R_{SP+/-} \geq 16$	-	1.25	-	V <sub>P-P</sub>
Total Harmonic Distortion	THD	@ 1kHz & 20mVp-p input	-	1	-	%

Note 1: Typical Values:  $V_{CCD} = V_{CCA} = 6\text{ V}$ ;  $V_{SSD} = V_{SSA} = 0\text{ V}$ ;  $T_A = 25\text{ }^\circ\text{C}$

Note 2: Except pins 23 and 27 which have internal pull-up resistors.

## Bonding Pad Diagram & Description of Bonding Pad Coordinates

Figure 5 AR9301-V2 Die Bonding Pad Diagram

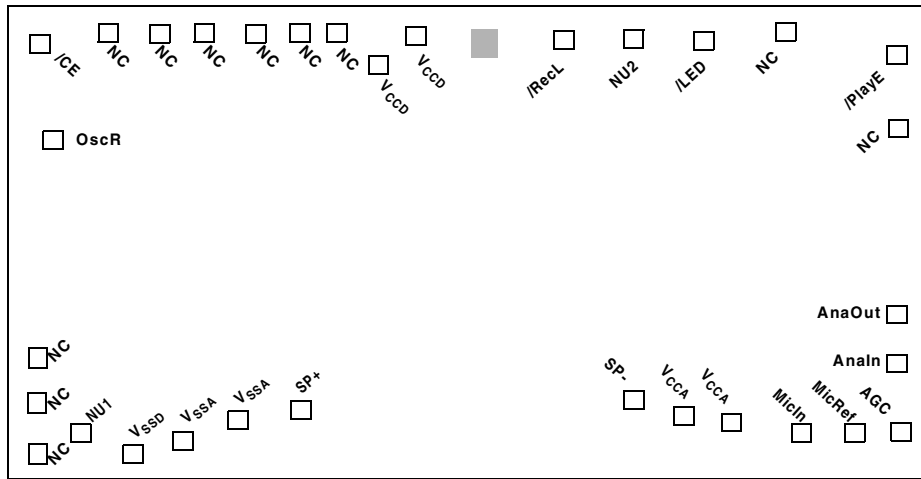

Notes:

Die diagram is with respect to die center ( $\mu\text{m}$ ).

Die Dimensions:  
 $x = 214 \pm 1$  mils  
 $y = 144 \pm 1$  mils

Die Thickness:  
 $13.8 \pm 1.0$  mils  
 $(350 \pm 25 \mu\text{m})$

Pad Opening:  
 $110 \mu\text{m}$   
 $4.3$  mils

Connect substrate to ground.

Table 5 AR9301-V2 Bonding Pad Coordinates

Pin	Pin Name	X Axis <sup>(Note)</sup>	Y Axis <sup>(Note)</sup>
/CE	Chip Enable	-2496.20	1565.80
OscR	Oscillator Frequency-Setting Resistor	-2459.55	729.80
NU1	Connect to Ground	-1808.45	-1496.10
VSSD	Digital Ground Supply	-1564.05	-1572.00
VSSA	Analog Ground Supply	-1384.05	-1548.70
VSSA	Analog Ground Supply	-1204.35	-1477.10
SP+	Non-Inverting Speaker Output	-707.15	-1390.00
SP-	Inverting Speaker Output	479.15	-1389.90
VCCA	Analog Power Supply	976.45	-1492.00
VCCA	Analog Power Supply	1190.40	-1523.70
MicIn	Microphone Input	1619.45	-1551.40
MicRef	Microphone Reference Input	2035.45	-1551.40
AGC	Automatic Gain Control	2487.45	-1551.40
AnaIn	Analog Signal Input	2487.45	-1049.90
AnaOut	Analog Signal Output	2487.45	-648.90
/PlayE	Edge-Activated Playback	2493.65	1371.10
/LED	LED Output	1430.70	1565.80
NU2	Connect to Ground	865.75	1565.80
/RecL	Level-Activated Record	258.15	1565.80
VCCD	Digital Power Supply	-229.40	1579.05
VCCD	Digital Power Supply	-510.80	1541.60

Note: With respect to die center ( $\mu\text{m}$ )

## APR9301-V2 DIP and SOP package pin-out

---

